

# "PROVIDENCE & PLYMOUTH" POST ASSEMBLY INSTRUCTIONS (3.1)

## Check boxes for these contents:

1. "Providence" Post
  2. Post Cap
  3. (5) 3" screws (white)
  4. (2) 2" screws (white)
  5. Touchup Kit
- (Optional) Mailbox support & mounting plate.  
(Optional) 3" Lantern Cap.

## Tools you will need:

- Wheelbarrow to mix concrete
- Tape measure
- Cordless Drill
- #2 Sq. drive bit
- 3/16" Drill bit
- Level
- Shovel

## Purchased separately

- Mailbox
- Pressure treated 6x6 or 4x4 - 84" long
- Two bags of pre-mix concrete

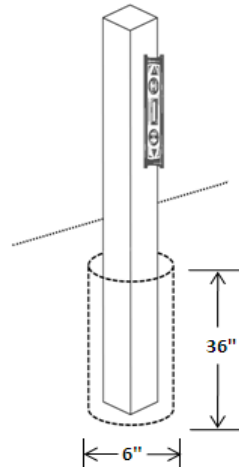

## STEP ONE - WOOD POST INSTALLATION

Dig a hole approx. 36" deep in the desired location. Verify the depth of the hole to ensure that the wood post will be buried 36" into the ground. Fill the hole 3/4 full with pre-mix concrete. Insert the post into the concrete and check for level. Allow time for the concrete to set, then fill in the remainder of the hole.

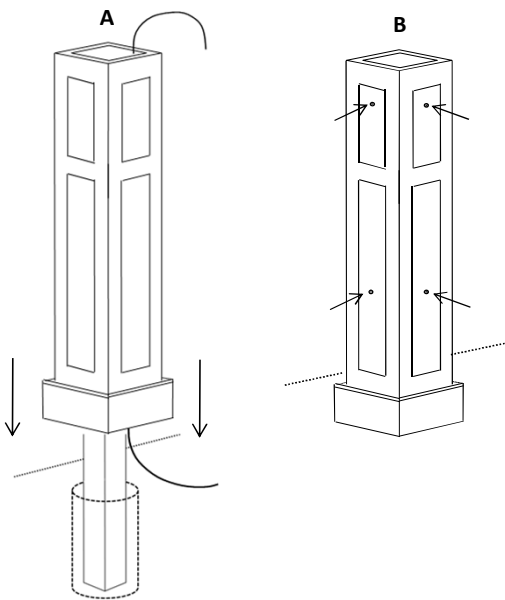

## STEP TWO - POST - WOOD POST INSTALLATION

- Slide the mailbox post assembly over the wood post. If you will be adding a Lantern to your post, make sure to add your wiring to the wood post before sliding over post. (see diagram A)
- Line up the one corner of the vinyl post against the wood post. (see top view diagram below) Pre-drill 3/16" pilot holes through vinyl only and fasten the two touching sides with the 3" screws, do not countersink screws. If your post includes a trim at the base of the post (not pictured) be sure to keep the screws above the trim. Make sure that the post cavity's are not on the street-mailbox side.

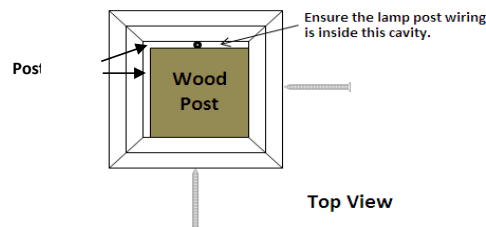

## STEP THREE - (OPTIONAL) INSTALLING LAMP

Attach post cap unto top of post using 2" screws. Be sure to thread wire through collar of post cap. Follow the instructions included with the lamp (purchased separately) and secure it to the round collar on top of the post. You may need to modify how it attaches to the collar. After the Lantern is installed, apply a continuous bead of (clear) silicone caulk around the bottom of the lantern.

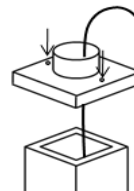

## STEP FOUR - (OPTIONAL) INSTALLING MAILBOX SUPPORT & MAILBOX

Attach the mailbox support and brace assembly unto the mailbox post at the required height using the 2" screws in the 3 pre-drilled holes. Refer to your local codes regarding the required height. (Approx. 42" to the bottom of the mailbox) Attach the provided mounting plate unto the support arm. Refer to the mounting holes in the mailbox for the location of the mounting plate. Note: Some modifications/cutting may need to be done to the mounting plate, depending on the mailbox size & style. Now place your mailbox on the mounting plate, and attach with the necessary hardware. (Provided on all "COA" mailboxes)

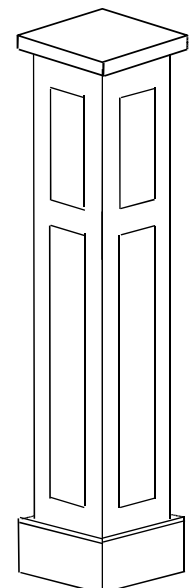
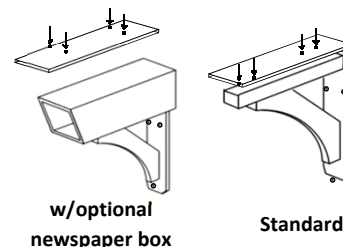

## Cleaning & Touchup.

After installation is complete you can clean your post with Clorox or other household detergent. There is also a touchup kit (included) to cover the hard to remove smudges. Keep touchup at a minimum.

